

Operating Manual

BROSA Type 0101 Compression Load Cell

Version: 02/2021

© 2021 BROSA AG, Tettngang, Germany

BROSA AG
Dr. Klein Straße 1
D-88069 Tettngang
Phone: +49(0)7542 93 35 0
Fax: +49(0)7542 93 35 35
info@brosa.net
www.brosa.net

BROSA Pte Ltd
25 Lorong Kilat #02-01
Singapore 598126
Phone: +65 6795 2324
Fax: +65 6795 2428
info.sg@brosa.net

BROSA B.V.
Galliershof 38
NL - 5349 BV Oss, Netherlands
Phone: +31 412 6146 02
Fax: +31 412 6146 86
info@brosa.nl

BROSA (Nanjing) Co., Ltd.
Jinma Lu 3, Maqun Scientific Park, Qixia District
210049 Nanjing
Phone: +86 (25)8222 4639
Fax: +86 (25)8222 4639
info.cn@brosa.net

Notes

Contents

1	General information	4
1.1	Safety instructions – Explanation of symbols:.....	4
2	Description of the BROSA compression load cell	5
2.1	Structure and functionality	5
2.2	Information on explosion protection	7
2.3	Label (nameplate, indication of measuring direction)	7
3	Advice on the safe handling of BROSA compression load cells	8
3.1	Handling	8
3.2	Installation and commissioning	8
3.2.1	General information	8
3.2.2	Additional information for operation in areas subject to explosion hazards	10
3.3	Operation and maintenance	10
3.3.1	Operation	10
3.3.2	Maintenance	11
3.4	Disassembly	11
3.5	Disposal	12

1 General information

Read the operating instructions and the product-specific documents carefully before commissioning the sensor.

Make sure that the sensor is fully suitable for the applications in question.

Improper use or any use other than intended may result in a malfunction of the sensor or undesirable effects in your application. For this reason, installation, electrical connection, commissioning and maintenance of the sensor may only be carried out by trained personnel authorized by the plant operator.

We also expressly point out that any liability is excluded if instructions in this documentation are disregarded.

Current certificates can be downloaded from the BROSA AG website.

Only the German version of this operating manual represents the original document.

1.1 Safety instructions – Explanation of symbols:



WARNING! This symbol indicates dangers that can lead to personal injury and property damage!

2 Description of the BROSA compression load cell

2.1 Structure and functionality

BROSA Type 0101 Compression Load Cells transmit and measure the compressive force between two plane-parallel surfaces, the distance between which the compression load cell mechanically bridges.

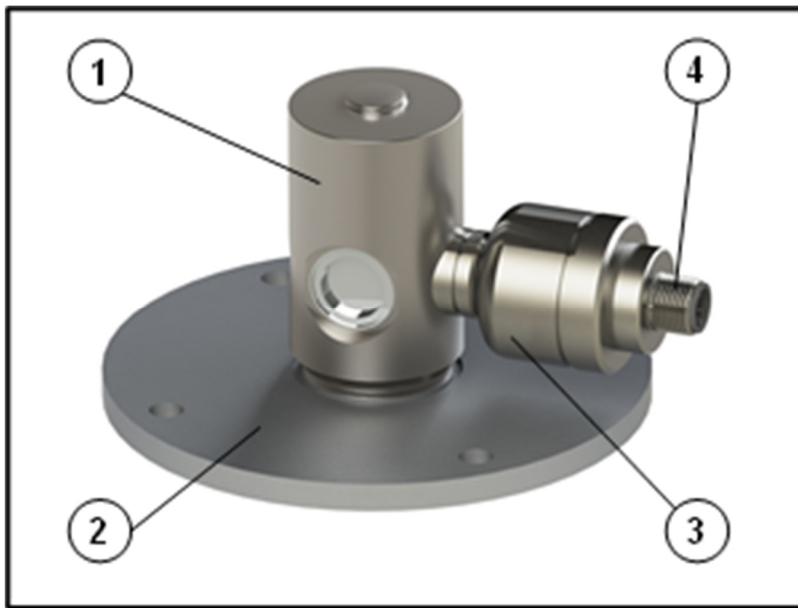

Fig. 1: Compression load cell

The compression load cell consists of a cylindrical measuring body (1) that absorbs the load to be measured and which is connected to the surrounding structure by an adapter element (2, e.g., tightening ring). In some cases, there is a connection support (3) firmly connected to the measuring body, on which - if not placed directly on the measuring body - the necessary elements for the electrical connection (plug or cable, 4) are attached and which - if not placed in the measuring body - contains the measurement electronics. The measuring body and connection support, if applicable, are made of stainless steel.

Versions with two measuring systems, either with output signals on separate connectors/cables or combined in one connector/cable, are available as options. More information can be found in the technical datasheets, which may be obtained free of charge from BROSA.

The use below the water surface is generally possible after testing and approval by BROSA, special requirements are the used materials, the tightness and the electrical connections. In addition, there is the possibility that the water pressure impacts the measurement result.

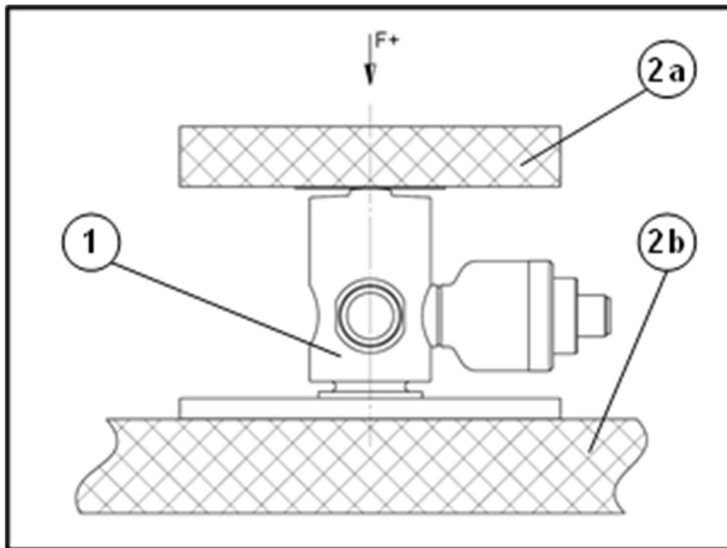

Figure 2: Installation conditions

The compression load cell (1) lies between the two force-transmitting surfaces of the surrounding structure (2a, 2b). The force F applied via the compression load cell is transmitted to the measuring electronics by evaluating the resulting deformation of the measuring body and output as an electrical signal. The two force-transmitting surfaces must be aligned plane-parallel to one another and maintain this property even under load. The surrounding structure should therefore be designed to be as rigid as possible. A spherical thrust bearing is advantageous for optimizing the force transmission. Special designs with integrated spherical bearings are available.

The following properties are recommended for the properties of the force-transmitting surfaces:

- Flatness deviation max. 0.05 mm
- Surface roughness max. Rz 6.3 or Ra 0.8
- Surface hardness min. 50 HRC



WARNING! An insufficiently rigid surrounding construction, inadequate force transmission or inadequate surface condition of the force-carrying surfaces affect the measurement result!

2.2 Information on explosion protection

The type 0101 compression load cell is optionally available in an intrinsically safe design for use in potentially explosive atmospheres. This is done using a 2-wire amplifier ExDANGmicro2W_***. The following specifications apply:

Certificate number:	BVS 16 ATEX E 041	IECEX BVS 16.0031
Ignition protection type:	Ex II 2G Ex ib IIC T4 Gb	Ex ib IIC T4 Gb
Voltage	30 V DC	30 V DC
Current	100 mA	100 mA
Power	750 mW	750 mW
Effective internal capacitance	24 nF + 0.3 nF/m	24 nF + 0.3 nF/m
Effective internal inductance	3 μ H + 1 μ H/m	3 μ H + 1 μ H/m
Ambient temperature	-40 to +80°C	-40 to +80°C



Use of intrinsically safe compression load cells in zone 0 is not allowed.

Current certificates can be downloaded from the BROSA AG website.

2.3 Label (nameplate, indication of measuring direction)

Each BROSA compression load cell is equipped with a nameplate containing the respective information applicable for the given product. It is attached to one of the outer surfaces of the measuring body or the connection support (see figure 3).



Figure 3: Nameplate position

3 Advice on the safe handling of BROSA compression load cells

 **WARNING!** Non-compliance with the following instructions can lead to sensor damage and/or impairment of measurement results. The analysis of an erroneous measurement can result in personal injury or material damage.

 **WARNING!** Despite their sturdy design, BROSA compression load cells may not be used for any other than the intended purpose (see. Section 1.1). With improper use, dangers to life and limb of the user or third parties and/or impairment of the device in which the compression load cell is implemented or other material assets can be caused.

3.1 Handling

 **WARNING!** BROSA sensors contain high-quality measurement electronics. Make sure they are handled carefully.

- BROSA compression load cells are delivered in transport-safe packaging. We recommend that you remove the sensors from the package immediately prior to installation.
- The mass of the compression load cell is to be observed when selecting appropriate handling equipment and/or lifting gear; it is indicated on the nameplate.
- BROSA compression load cells must be secured against falling. Do not throw sensors!
- Use as a tool (e.g., impact, slotting or lever tool) is not permitted; it can cause damage to the sensor and thus falsify the measurement results.

3.2 Installation and commissioning

3.2.1 General information

We recommend taking the following actions in the given order using the “four-eye principle”.

- a) Inspecting the sensor - measuring point assignment: It must be ensured that the sensor to be installed is designed for use at the intended measuring point. For this purpose, check information on the nameplate, in particular the item or the

identification number and the measuring range, against the data of the measuring point.



WARNING! A sensor not designed for the particular measuring point must not be installed.

- b) Inspection of the sensor for intactness and function: It must be ensured that the sensor to be incorporated is free of damage of any kind.



WARNING! A damaged sensor must not be installed!

- c) Installation of the sensor in the measuring point: The compression load cell is to be aligned on the intended contact surface according to the offer drawing.



WARNING! The compression load cell must not be driven in using impact tools!

After alignment, the compression load cell must be secured against movement and rotation using the elements provided for this purpose. Attention must be paid to the correct alignment of the compression load cell to the intended measuring direction (see front mark, compare Section 1.2.)



WARNING! A misaligned sensor leads to erroneous measurement results!

- d) Establishment of electrical connection: The elements on the sensor for the electrical connection are to be connected to the power supply, the earth connection if necessary, and the evaluation system of the device. In doing so, the information given on the nameplate for plug or cable assignment and, if applicable the installation guidelines of the cable, are to be observed.



WARNING! An incorrect or incomplete electrical connection impairs or prevents measurement.

- e) Functional check: After completed mechanical (see c) and electric (see d) installation, load on the sensor is to be applied over the entire measuring range; the output measurement signals are to be subjected to a plausibility check.

 **WARNING!** If due to unusual events (e.g., deformation or unusual noise), measurement results are considered implausible or there is suspicion that the sensor is malfunctioning for any other reason, it must not be put into operation.

3.2.2 Additional information for operation in areas subject to explosion hazards

 Only those sensors with the corresponding labels are approved for use in areas subject to explosion hazards.

If the open cable end is connected inside an area subject to explosion hazards, the connection must be inside a terminal box/switching cabinet certified in accordance with the ATEX-directive. If it is connected outside an area subject to explosion hazards, it must be in line with the general requirements for electrical equipment.

3.3 Operation and maintenance

3.3.1 Operation

BROSA compression load cells operate automatically; attaching tools is not required for operation. Direct manual intervention by the operator is not necessary; there are therefore no requirements for the operator to wear protective equipment during operation. However, the relevant requirements for the device in which the compression load cell is implemented must be observed.

BROSA compression load cells emit neither noise nor non-ionizing radiation.

Operation of BROSA compression load cells is permitted only within the parameters and properties given in the technical datasheets and on the nameplate. These are, among others:

- Measuring range
- Temperature range
- Permissible supply voltage
- Electrical protection class
- Material

It must be ensured that no parasitic influences such as forces transverse to the measuring direction are transmitted via the compression load cell.

Inductive or capacitive coupling with the connection cable(s) of the sensor can distort the measurement result and must be avoided. Some examples of these kinds of couplings can

be caused e.g., by unfavourable cable routing (parallel power lines, frequency converters, transformers, motors, incorrect grounding/shielding and the like).

When performing electric welding in the vicinity of the sensor, all connections must be disconnected and isolated. It must be ensured that no welding current is flowing through the sensor.

 **WARNING!** Operation outside the specified parameters or contrary to existing properties or improper use can damage the sensor and cause it to fail or lead to faulty measuring results. If the sensor is overloaded, this can lead to the whole machine being equally overloaded and possibly endangering its stability.

3.3.2 Maintenance

As sensors, BROSA compression load cells are basically maintenance-free. As load-transmitting elements, however, they are subject to mechanical stress, requiring regular inspections of the fault-free state of each compression load cell. The intervals between inspections depend on the intensity of use and must be determined by the end-user.

An inspection includes the following points:

- Visual inspection for damage to the measuring body and wiring as well as contamination.
- Function test/plausibility check

The causes of existing errors are to be identified and remedied. If the test indicates an improper sensor state, it must be taken out of operation. If a malfunction or damage is detected on the sensor, it must be sent to the manufacturer's factory for diagnosis and, if necessary, repaired.

 **WARNING!** The sensor may only be repaired at the factory. Intervention (e.g., opening, mechanical processing and the like) done by parties other than the manufacturer means the safe operation of the sensor is no longer ensured and voids the guarantee and warranty.

3.4 Disassembly

We recommend performing the following actions in the order given.

- a) Establishment of a load-free state at the measuring point: The compression load cell is to be unloaded before removal.

 **WARNING!** Removal of a compression load cell under load poses serious dangers to the life and limb of bystanders and can cause major damage. This is therefore not permitted.

- b) Undoing the electrical connection
- c) Remove the mechanical securing elements
- d) Removal of the compression load cell

 **WARNING!** If the compression load cell is to be reused, it must not be removed using impact tools!

3.5 Disposal

If the end of the service life is reached, the compression load cell is to be disposed of in an environmentally friendly way. Since the non-metallic components are a small proportion compared to the mass of the compression load cell, it can be recycled as a whole as scrap steel. BROSA sensors are usually made of stainless steel and can be disposed of accordingly.

If the sensor is stored before final disposal, an appropriate storage location is to be selected which prevents harmful substances from entering the environment. If necessary, the sensor must be cleaned.

 **WARNING!** BROSA compression load cells contain traces of environmentally hazardous substances. This is also true of the impurities created during use. Contamination of the environment by these substances is to be prevented.

Translation of the original



EC/EU Declaration of Conformity

in terms of Directives
2006/42/EC, Annex II Part 1 A,
2014/30/EU, Annex IV and
2014/34/EU, Annex X

Manufacturer: **BROSA AG**
Dr.-Klein-Straße 1
D-88069 Tett nang

On our own responsibility we hereby declare the products according to design/type

Compression load cell type 0101
from serial number 16040001 onwards

to comply with the relevant regulations of the following directives:

2006/42/EC Machinery Directive
2014/30/EU EMC Directive

Products according to the mentioned design as an ATEX intrinsically safe version are marked as such and additionally comply with the relevant regulations of the following directive:

2014/34/EU ATEX Directive

The type examination related with the latter directive has been carried out by the following notified body:

DEKRA EXAM GmbH BVS 03 ATEX E 241
Dinnendahlstraße 9
D-44809 Bochum Notified Body No. 0158

The requirements for production and testing of the product are defined in a quality and environmental management system certified according to ISO 9001 and ISO 14001.

Page 2 of this Declaration contains the standards harmonized with the mentioned Directives and applied to the products according to the mentioned design/type.

Tett nang, April 20th, 2016

Martin Wagner
CEO

Translation of the original



List of applied, harmonized standards

2006/42/EG	
EN ISO 13849-1:2008 +AC:2009	Safety of machinery – Safety-related parts of control systems – Part 1: General principles for design
2014/30/EU	
EN 61000-6-2:2005 +AC:2005	Electromagnetic compatibility (EMC) – Part 6-2: Generic standards – Immunity for industrial environments
EN 61000-6-3:2007 +A1:2011 +AC:2012	Electromagnetic compatibility (EMC) – Part 6-3: Generic standards – Emission standard for residential, commercial and light-industrial environments
EN 61326-1:2013	Electrical equipment for measurement, control and laboratory use – EMC requirements – Part 1: General requirements
EN 61326-2-3:2013	Electrical equipment for measurement, control and laboratory use – EMC requirements – Part 2-3: Particular requirements – Test configuration, operational conditions and performance criteria for transducers with integrated or remote signal conditioning
2014/34/EU	
EN 60079-0:2012 +A11:2013	Explosive atmospheres – Part 0: Equipment – General requirements
EN 60079-11:2012	Explosive atmospheres – Part 11: Equipment protection by intrinsic safety "i"

Person authorized to compile the technical files:

Joachim Fellner
Dr.-Klein-Straße 1
D-88069 Tett nang

End of EC Declaration of Conformity