

Operating Manual

BROSA Type 0207 Bearing Force Transducer

Version: 01/2020

© 2018 BROSA AG, Tettngang, Germany

BROSA AG
Dr. Klein Straße 1
D-88069 Tettngang
Phone: +49(0)7542 93 35 0
Fax: +49(0)7542 93 35 35
info@brosa.net
www.brosa.net

BROSA Pte Ltd
25 Lorong Kilat #02-01
Singapore 598126
Phone: +65 6795 2324
Fax: +65 6795 2428
info.sg@brosa.net

BROSA B.V.
Galliershof 38
NL - 5349 BV Oss, Netherlands
Phone: +31 412 6146 02
Fax: +31 412 6146 86
info@brosa.nl

BROSA (Nanjing) Co., Ltd.
Jinma Lu 3, Maqun Scientific Park, Qixia District
210049 Nanjing
Phone: +86 (25)8222 4639
Fax: +86 (25)8222 4639
info.cn@brosa.net

Notes

Contents

1	General information.....	4
1.1	Safety instructions – Explanation of symbols:.....	4
2	Description of the BROSA Bearing Force Transducer	5
2.1	Structure and functionality	5
2.2	Information on explosion protection.....	6
2.3	Label (nameplate, indication of measuring direction).....	7
3	Advice on safe handling of BROSA Bearing Force Transducers	8
3.1	Handling.....	9
3.2	Installation and commissioning.....	9
3.2.1	General information.....	9
3.2.2	Additional information for operation in areas subject to explosion hazards	10
3.3	Operation and maintenance	12
3.3.1	Operation	12
3.3.2	Maintenance	13
3.4	Disassembly.....	13
3.5	Disposal	14

1 General information

Read the operating instructions and the product-specific documents carefully before commissioning the sensor.

Make sure that the sensor is fully suitable for the applications in question.

Improper use or any use other than intended may result in malfunction of the sensor or undesirable effects in your application. For this reason, installation, electrical connection, commissioning and maintenance of the sensor may only be carried out by trained personnel authorized by the plant operator.

We also expressly point out that any liability is excluded if instructions in this documentation are disregarded.

Only the German version of this operating manual represents the original document.

1.1 Safety instructions – Explanation of symbols:



WARNING! This symbol indicates dangers that can lead to personal injury and property damage!

2 Description of the BROSA Bearing Force Transducer

2.1 Structure and functionality

The BROSA Type 0207 Bearing Force Transducer is used to record the bearing force in bearings in or on machines and devices of all kinds. Figure 1 shows the typical layout:

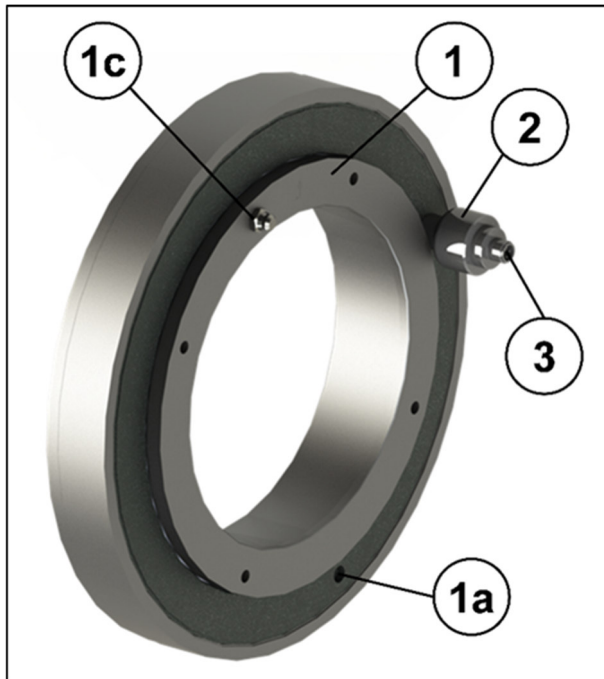

Figure 1: Bearing force transducer

The bearing force transducer consists of a cylindrical measuring body (1), which absorbs the load to be measured and exhibits the properties for torsional and axial securing (1a) as well as a connection support (2) firmly connected to the measuring body in some cases, on which - if not placed directly on the measuring body - the necessary elements for the electrical connection (plug or cable, 3) are attached and which - if not placed in the measuring body - contains the measurement electronics. Optionally, the measuring body can contain elements to lubricate the bearing (1c).

Figure 2 shows the typical installation conditions:

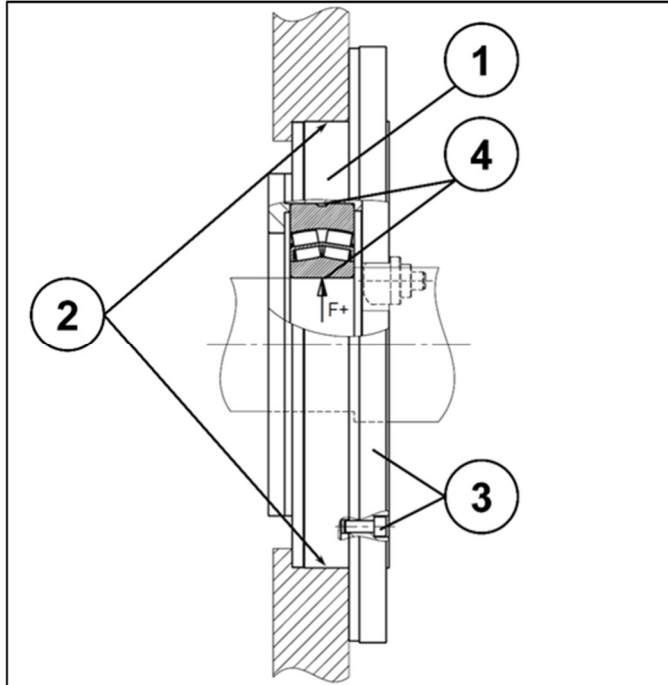

Figure 2: Installation conditions

The bearing force transducer (1) is inserted into the correspondingly dimensioned mounting holes (2) of the bearing position and secured against movement (3) using the features mentioned (see Fig. 1). A defined force application surface (4) is located on the inside diameter of the bearing force transducer. The force F applied there is transmitted to the measuring electronics by evaluation of the resulting deformation of the measuring body and output as an electrical signal.

Versions with two measuring systems, either with output signals on separate connectors/cables or combined in one plug/cable, are available as options. More information can be found in the technical data sheets, which can be obtained free of charge from BROSA.

2.2 Information on explosion protection

The type 0207 bearing force transducer is optionally available in an intrinsically safe version for use in potentially explosive atmospheres. This can be done in 2-wire technology using the ExDANGmicro2W*** amplifier. The following specifications apply:

	Amplifier ExDANGmicro2W***
Ignition protection type:	Ex II2G Ex ib IIC T4 Gb Ex ib IIC T4 Gb
Certificate number:	BVS 16 ATEX E 041 IECEX BVS 16.0031
Safety-related limit values: <ul style="list-style-type: none"> • Maximum voltage U_i • Maximum current I_i • Indoor capacity C_i • Internal inductance L_i 	= 30V DC = 100 mA = 24 nF + 0.3 nF/m = 3 μ H + 1 μ H/m



Use of intrinsically safe bearing force transducers in zone 0 is not allowed.

2.3 Label (nameplate, indication of measuring direction)

Each BROSA Bearing Force Transducer is provided with a nameplate containing the information applicable for each variety. Depending on the design, it can either be attached to the front (Fig. 3, 1a) or to a connected connection carrier (Fig. 3, 1b).

The measuring direction is indicated on the front side with an arrow (Figure 3, 2).

The measuring direction is indicated on the front side with an arrow (Figure 3, 2).

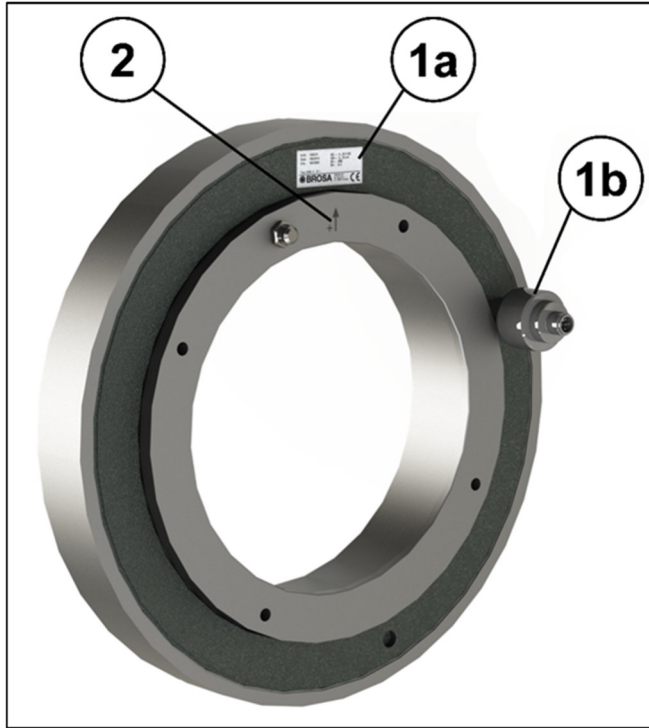





Figure 3: Nameplate positions, measuring direction

3 Advice on safe handling of BROSA Bearing Force Transducers

 **WARNING!** Non-compliance with the following instructions can lead to sensor damage and/or impairment of measurement results. The analysis of an erroneous measurement can result in personal injury or material damage.

 **WARNING!** Despite their sturdy design, BROSA Bearing Force Transducers may not be used for anything other than the intended purpose (see. Section 1.1). Dangers to life and limb of the user or third parties and/or impairment of the device in which the bearing force transducer is implemented, or other material assets can be caused by improper use.

3.1 Handling

 **WARNING!** BROSA sensors contain high-quality measurement electronics. Make sure they are handled carefully.

- BROSA Bearing Force Transducers are delivered in transport-safe packaging. We recommend that you remove the sensors from the package immediately prior to installation.
- The mass of the force measurement axis is to be observed when selecting appropriate handling equipment and/or lifting gear; it is indicated on the nameplate.
- BROSA Bearing Force Transducers must be secured against falling. Do not throw sensors!
- Use as a tool (e.g. striking, slotting or lever tool) is not permitted; it can cause damage to the sensor and thus falsify the measurement results.

3.2 Installation and commissioning

3.2.1 General information

We recommend taking the following actions in the given order using the “four-eye principle”.

- a) Checking the sensor-measuring point assignment: It must be ensured that the sensor to be installed is designed for use at the intended measuring point. For this purpose, check information on the nameplate, in particular the item or the identification number and the measuring range, against the data of the measuring point.

 **WARNING!** A sensor not designed for the particular measuring point must not be installed.

- b) Inspection of the sensor for intactness and function: It must be ensured that the sensor to be incorporated is free of damage of any kind.

 **WARNING!** A damaged sensor may not be installed!

- c) Installation of the sensor in the measuring point: The bearing force transducer is to be aligned on the intended contact surface according to the offer drawing.

 **WARNING!** The bearing force transducer must not be aligned using impact tools!

After alignment, the bearing force transducer must be secured against movement and twisting with the appropriate elements. Attention must be paid to the correct alignment of the bearing force transducer with the intended measuring direction (see front marking, cf. Section 1.2).

 **WARNING!** A misaligned sensor leads to erroneous measurement results!

- d) Establishment of electrical connection: The elements on the sensor for the electrical connection are to be connected to the power supply, the earth connection if necessary, and the evaluation system of the device. In doing so, the information given on the nameplate for plug or cable assignment and, if applicable the installation guidelines of the cable, are to be observed.

 **WARNING!** An incorrect or incomplete electrical connection impairs or prevents measurement.

- e) Functional check: After completed mechanical (see c) and electric (see d) installation, load on the sensor is to be applied over the entire measuring range; the output measurement signals are to be subjected to a plausibility check.

 **WARNING!** If, due to unusual events (e.g. deformation or unusual noise), measurement results are considered implausible or there is suspicion that the sensor is malfunctioning for any other reason, it must not be put into operation.

3.2.2 Additional information for operation in areas subject to explosion hazards

 Only those sensors with the corresponding labels are approved for use in areas subject to explosion hazards.

If the open cable end is connected inside an area subject to explosion hazards, the connection must be inside a terminal box / switching cabinet certified in accordance with ATEX-directive. If it is connected outside an area subject to explosion hazards, it must be in line with the general requirements for electrical equipment.

3.2.2.1 Type 0207 in an intrinsically safe version

The sensors with ExDANGmicro2W*** amplifier must be installed according to the following specifications:

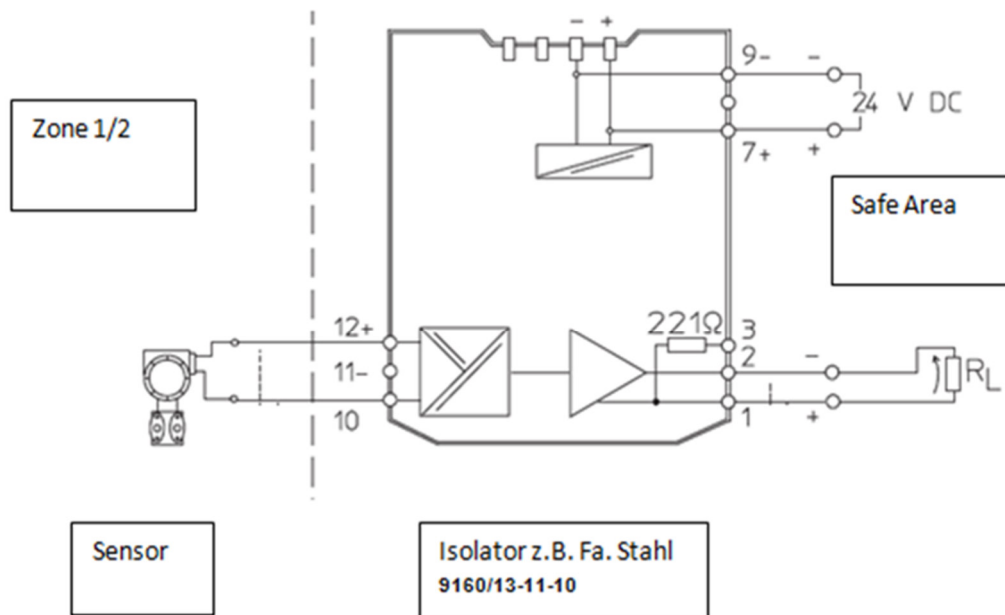

Figure 6: Connection example of sensor Ex i with Ex DANGmicro2W*** amplifier

The supply and the measurement signal are guided over isolation amplifiers in the areas subject to explosion hazards. Isolation amplifiers from other manufacturers can also be used if they meet the safety-related limit values.

During the installation, the distinction with regard to the insulation resistance of the strain gauge resistance bridge against sensor spring body must be taken into account. The amplifier type ExDANGmicro2W_A** is to be regarded as separate from the spring body. The amplifier type ExDANGmicro2W_B** is to be regarded as connected to the spring body in case of error.

The laying of the connection cable with the amplifier type ExDANGmicro2W_* B2 and type ExDANGmicro2W_* B4 requires protection against damage and tensile load, guaranteed by suitable installation.

The complete list of possible amplifier configurations can be found in the certificate.

3.3 Operation and maintenance

3.3.1 Operation

BROSA Bearing Force Transducers operate automatically; attaching tools is not required for operation. Direct manual intervention by the operator is not necessary; there are therefore no requirements for the operator to wear protective equipment during operation. However, the relevant requirements for the device in which the bearing force transducer is implemented must be observed.

BROSA Bearing Force Transducers emit neither airborne acoustic noise nor non-ionising radiation.

Operation of BROSA Bearing Force Transducers is permitted only within the parameters and properties given in the technical data sheets and on the nameplate. These are, among others:

- Measuring range
- Temperature range
- Permissible supply voltage
- Electrical protection class
- Material

It must be ensured that no parasitic influences such as forces or torques transverse to the direction of measurement are transmitted via the bearing force transducer.

Inductive or capacitive coupling with the connection cable(s) of the sensor can distort the measurement result and must be avoided. Some examples of these kinds of couplings can be caused e.g. by unfavourable cable routing (parallel power lines, frequency converters, transformers, motors, incorrect grounding/shielding and the like).

When performing electric welding in the vicinity of the sensor, all connections must be disconnected and isolated. It must be ensured that no welding current is flowing through the sensor.

 **WARNING!** Operation outside the specified parameters or contrary to existing properties or improper use can damage the sensor and cause it to fail or lead to faulty

measuring results. If the sensor is overloaded, this can lead to the whole machine being equally overloaded and possibly endangering its stability.

3.3.2 Maintenance

In its capacity as a sensor, BROSA Bearing Force Transducers are maintenance-free. As load-transmitting elements, however, they are subject to mechanical stress, requiring regular inspections of the fault-free state of each bearing force transducer. The interval between inspections depend on the intensity of use and must be determined by the end user.

An inspection includes the following points:

- Visual inspection for damage to the measuring body and wiring as well as soiling
- Function test / plausibility check

The causes of existing errors are to be identified and remedied. If the test indicates an improper sensor state, it must be taken out of operation. If a malfunction or damage is detected on the sensor, it must be sent to the manufacturer's factory for diagnosis and, if necessary, repaired.

 **WARNING!** The sensor may only be repaired at the factory. Intervention (e.g. opening, mechanical processing and the like) done by parties other than the manufacturer means the safe operation of the sensor is no longer ensured and voids the warranty.

3.4 Disassembly

We recommend performing the following actions in the order given.

- a) Ensuring freedom from loads at the measurement position: The normal force transducer should be unloaded before disassembly.
- a) Ensuring freedom from loads at the measurement position: The bearing force transducer should be unloaded before disassembly.

 **WARNING!** The disassembly of a bearing force transducer under load leads to high risks to life and limb of persons in the vicinity and can cause severe material damages. This is therefore not permitted.

- b) Undoing the electrical connection
- c) Remove the mechanical securing elements
- d) Removal of the bearing force transducer

 **WARNING!** If the bearing force transducer is to be reused, it must not be removed with the aid of impact tools!

3.5 Disposal

If the end of the service life has been reached, the bearing force transducer is to be taken to an environmentally friendly disposal facility. Since the non-metallic components constitute a small part of the mass of the bearing force transducer, the rod may be recycled as a whole as scrap steel. Assignment as stainless steel scrap is preferable.

If the sensor is stored before final disposal, an appropriate storage location is to be selected which prevents harmful substances from entering the environment. If necessary, the sensor must be cleaned.

 **WARNING!** BROSA Bearing Force Transducers contain traces of environmentally hazardous substances. This is also true of the impurities created during use. Contamination of the environment by these substances is to be prevented.